

M/02/F & M/02/FA Piezoelectric Dynamic Pressure Transducer

5nC/bar nom. 46-56.5gm 250°C max temp

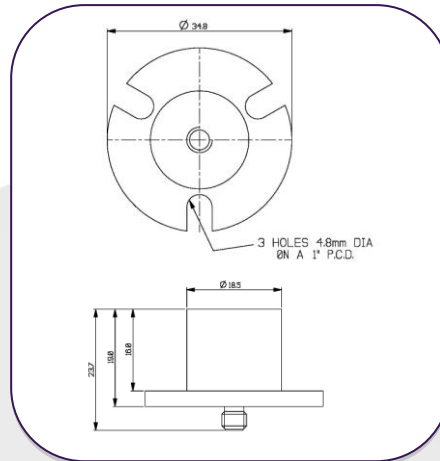

M/02/F



M/02/FA

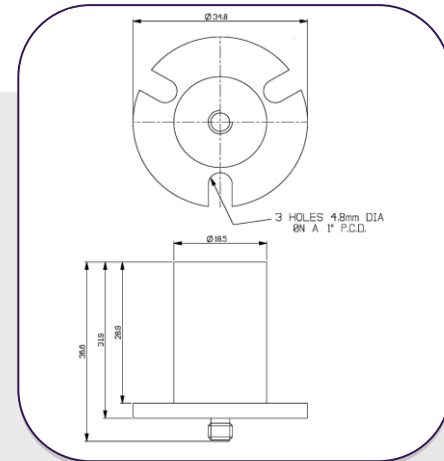

A smaller pressure transducer, doubling acoustic bandwidth, but at expense of 14dB reduction in sensitivity, thus 0.01pC noise equivalent acoustic signal threshold increases to 82dB (2.5mbar) M/02 application areas include air blast measurement, combustion gas acoustic measurement, fluid flow dynamics. Signals may be superimposed upon high static pressure backgrounds. Transducers are calibrated at ambient pressure.

STABILITY

Piezoceramics are subject to a logarithmic sensitivity decay vs. time. Exposure of piezoceramics to initial high pressure, temperature produces an initial sensitivity loss. Thereafter, subject to these initial conditions not being subsequently exceeded stability is exceedingly high, of the order 1 or 2%/1st yr.

Transducers subject to high pressure/temperature should be thermally and load cycled to in build minimal long term degradation.

Options

- charge vs. pressure up to 200bar
- wideband temperature calibration -50/+300°C
- proof pressure test of transducers, transducer/cable assemblies to 150bar
- hermetic Microdot, TNC & 7/16 UNS 2 pole connectors
- integral hardline cable termination
- case isolated signal for cmr
- Intrinsic Version EEx ia II BT2 (Tamb.=300°C),

ENVIRONMENTAL

M/02s have a variety of signal outlet options to cater for more extreme operating conditions. These encompass fluid immersion of transducer and cable, environments hazardous to cabling where cable armouring may be necessary and

Temperature Response

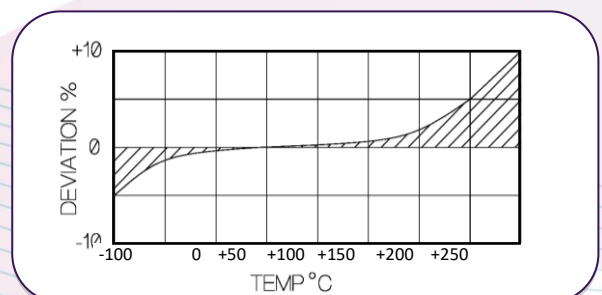

Please note: For information and reference only. Data should not be used as pass / fail criteria for calibration purposes

DJB Instruments (UK) Ltd
Finchley Avenue,
Mildenhall, Suffolk IP28 7BG

Tel +44 (0)1638 712 288
Email sales@djbstruments.com
Web www.djbstruments.com

A UK company with UK-based manufacturing, assembly and calibration in-house.

DJB Iss.1.2018



FM11310

M/02/F & M/02/FA Piezoelectric Dynamic Pressure Transducer

5nC/bar nom. 46-56.5gm 250°C max temp



Model	Metric		Imperial	
	M/02/F	M/02/FA	M/02/F	M/02/FA
Pressure Sensitivity @ 20°C	0.51nC/bar		5nC/bar	
Vibration Sensitivity pC/g @ 20°C	23 max	2.5 max	23 max	2.5 max
Capacitance nF	1.4 / 1.9	2.8 / 5.0	1.4 / 1.9	2.8 / 5.0
Resonant Frequency kHz	90	70	90	70
Temperature Range	-50/+250°C		-58/+482°F	
Press./Vib Sensitivity Deviation re 20°C	-5% @ -50°C +15% @ +250°C		-5% @ -58°F +15% @ +482°F	
Max Static Wkg. pressure, bar	200		200	
Case Material	Stainless Steel 303 S31		Stainless Steel 303 S31	
Weight	46gm	56.5gm	1.62oz	1.99oz
Connector	Microdot skt 10/32 UNF thd		Microdot skt 10/32 UNF thd	
Case Seal	Welded, hermetic diaphragm		Welded, hermetic diaphragm	
Size	23.7mm x 34.8mm	36.6mm x 34.8mm	0.93in x 1.37in	1.44in x 1.37in

Please note: For information and reference only. Data should not be used as pass / fail criteria for calibration purposes

DJB Instruments (UK) Ltd

Finchley Avenue,
Mildenhall, Suffolk IP28 7BG

Tel +44 (0)1638 712 288
Email sales@djbstruments.com
Web www.djbstruments.com

A UK company with UK-based manufacturing, assembly and calibration in-house.

DJB Iss.1.2018



FM11310